

Vocational Training Centre

St. Francois of Assise



PICTURES OF SOME HARDWARE

(Reference lists of materials)

CARPENTRY - WOODWORKING

By

Joseph Charles Dorestant

November 2011

CARPENTRY-WOODWORKING

Materials Part 1

INDIVIDUAL HARDWARE

A- TOOLS

#6 Set of wood chisels (1/4 to 6 inches)



#7 Soft mallet



#17 Adjustable scraper



#21 Pincers (220 mm)

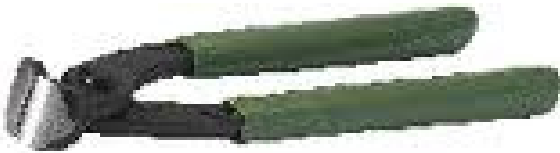

#24 and #25 Hunting highlight (1/16 and 1/8 inches)



#26 Lime knife-files for metal tools



#27 Clamps flexible hose (3/4 inch)



INDIVIDUAL HARDWARE

B- INSTRUMENTS ET ACCESORIES

#1 Combination square (300mm)

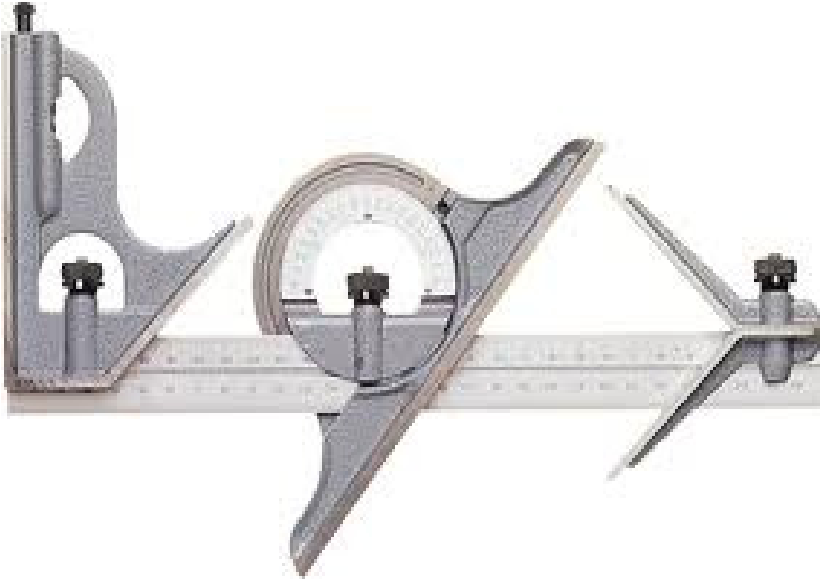

#2 Trusquin wood



COLLECTIVE HARDWARE

C- EQUIPMENT AND ACCESSORIES

#1 Electric drill, 0.75 HP motor, 220 volt, three phase



#2 Cross-clamps



#4 Bench Grinders, 3000 RPM, 110/220 volt motor



#5 Wheel semi rough



#6 Trainer wheel



#9 Vise wood (7 inches)



CARPENTRY-WOODWORKING

Materials Part 2

COLLECTIVE HARDWARE

A-TOOLS

#1 Diamond (to prepare the wheels)



#2 Blade slit (carbide 10 inches)



#3 General purpose blade (10 inches)



#4 Saw set Groove



#5 Knife set Groove



#8 Knife set quarter round

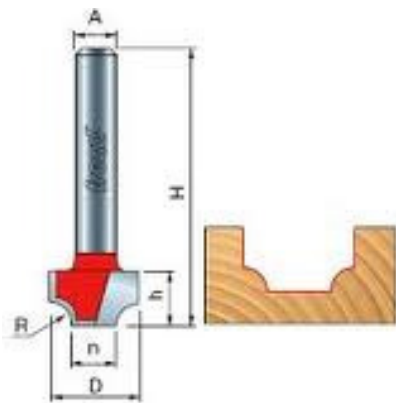

9, #10 and #11 Knife set throat and knife with tongue and groove male / female



#12, #13 and #14 Wood blade (3/8 - 1/2 - 1/4 inches)



#15 Hard to sand



#16 Set of wood drill



#17 Foret (1/8 to 1/4 inch)



#21 Wick stud HSS (3/8 inch)

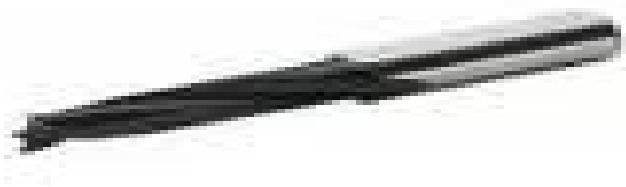

#22 to #26 Set of wood cutters (3/8 - 1/4 - 1/2 - 3/4 inches)



#27 Jack plane (14x2 inches)

